

TANDEM runners for any application

552 single and 562 full extension

TANDEM runners are designed with the American 3" increment cabinet depth system in mind. This feature permits overlay or inset applications using the same runner. Both series have full length profiles that make installation in panel and face-frame cabinets possible.

TANDEM provides interchangeability. One drawer box can be used with either a single or full extension runner in the same cabinet opening. TANDEM also provides compatibility with Blum's SOLO standard extension concealed drawer runners. (see page 5)

General specifications

Integrated one piece runner profiles

- Zinc coated steel.
- Concealed roller carriage mechanism with permanently lubricated, synthetic rollers.
- Blumatic spring loaded self-closing action.
- Force guided right side with 1/4" wide rear hook and +/-1/16" tolerance left side with 3/16" wide rear hook.

Locking Devices

- Zinc die cast with synthetic, spring-loaded release levers.
- Force guided right device and +/-1/16" self-adjust tolerance on left device.
- Self-adjusting drawer length tolerance.
- Tool-free drawer height adjustment.

Rear mount brackets

- Zinc-plated steel with depth and side-to-side self-alignment.

Weight capacities*

- 75 lbs **Dynamic** for 100,000 open/close cycles
- 100 lbs **Static** applied to half extended drawer

* As per ANSI/BHMA 156.9-1994 specifications on a 21" length drawer.

562 series concealed drawer runners

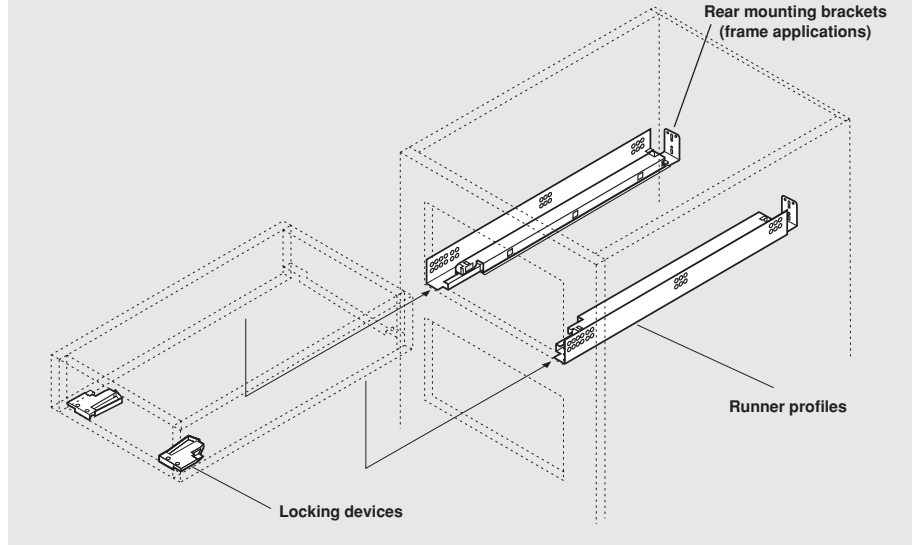

552 series concealed drawer runners

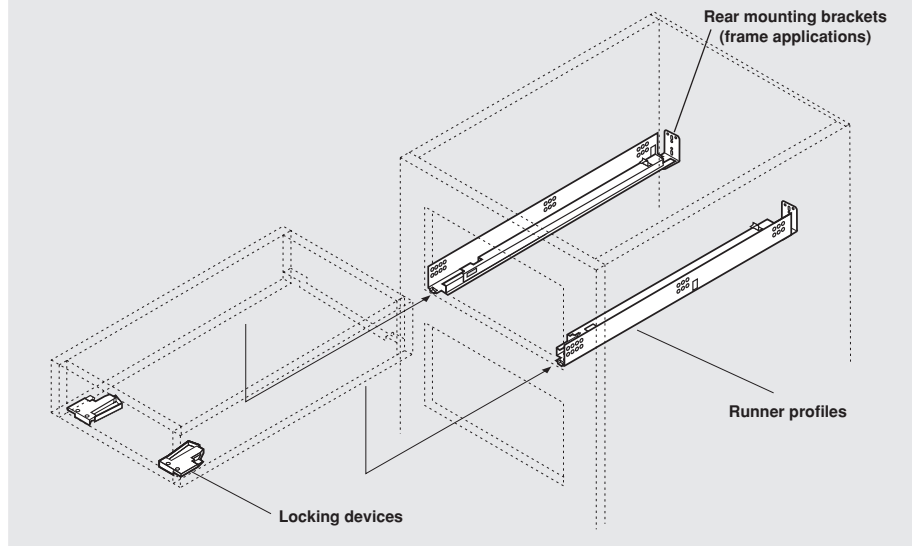

TANDEM drawer removal and height adjustment

