

Technical Information

100/300 Hinge Cup

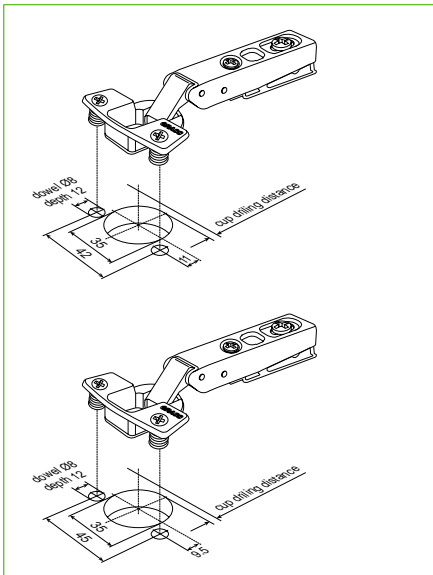

3000 Hinge Cup

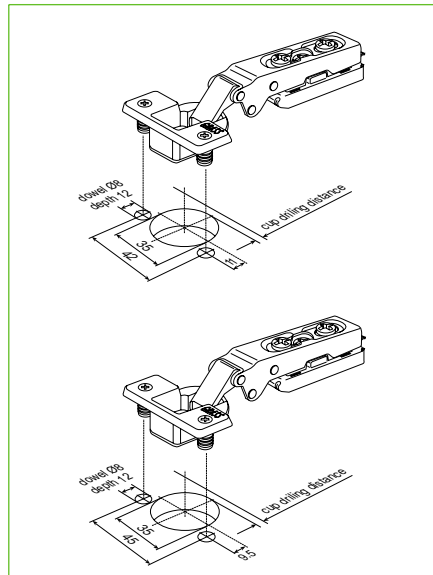

TEC 860 Hinge Cup

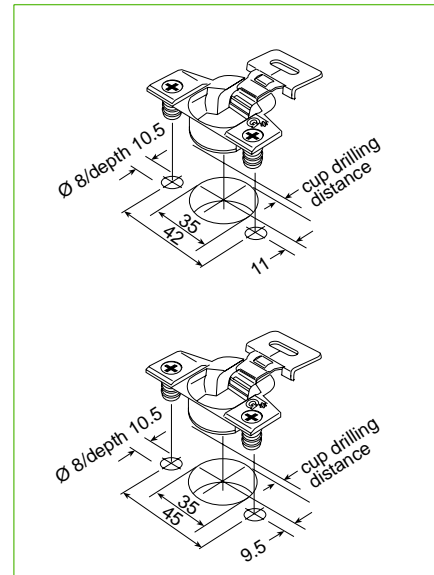

300/3000 Glass Door Hinge Cup

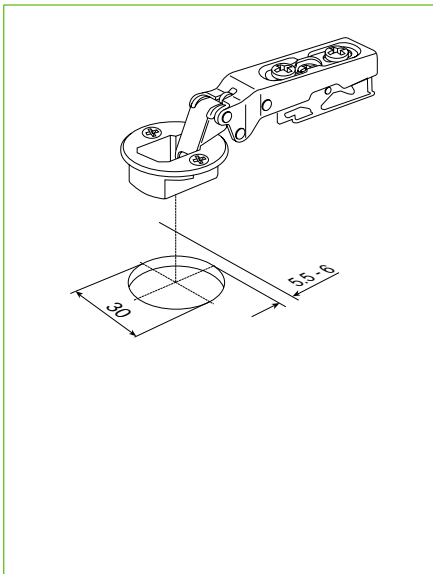

TEC 830/831 Hinge Cup

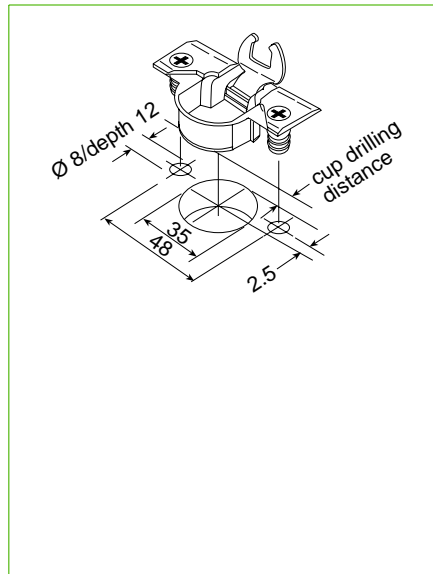

Atlas 961/963 Hinge Cup

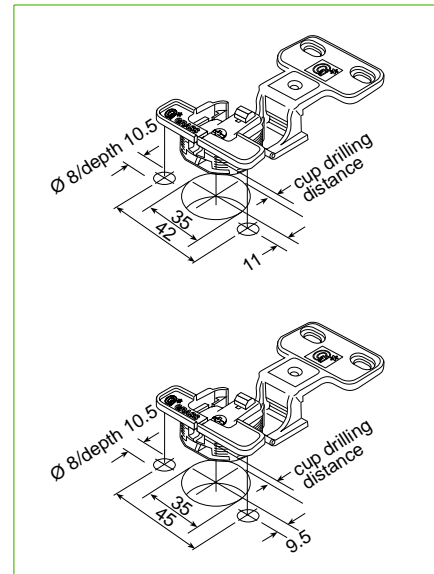

500 Butterfly Hinge Cup

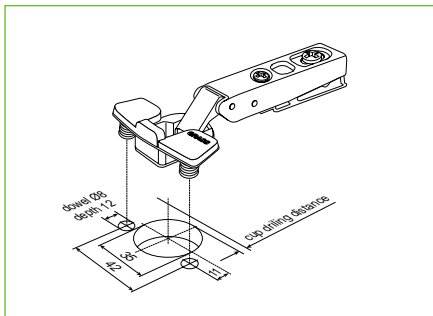

Adjustment Features

The Grass Hinge Series offers 2 and 3-dimensional adjustment, allowing for corrections of assembly and installation inaccuracies.

The adjustment technology is integrated into the hinge arm and/or baseplate and allows for independent screw action.

- ① Side Adjustment
- ② Depth Adjustment
- ③ Height Adjustment

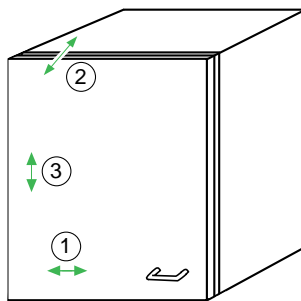

**G300 Snap-on Series
2-Dimensional Adjustable Hinge
with Height Adjustable Baseplate**

Allows for three-way adjustment. The side and depth adjustment are located on the hinge arm. Height adjustable baseplate combine to make 3-dimensional adjustment.

Use #2 POZIdrive screwdriver to adjust screws.

- ① Side Adjustment
- ② Depth Adjustment
- ③ Height Adjustment

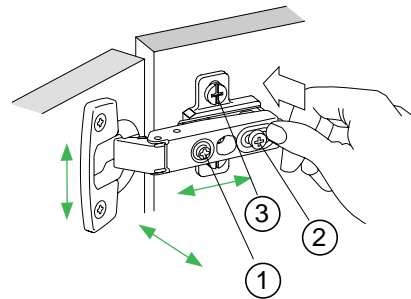

**TEC 830/TEC 860
Hinge Adjustments**

Allows for 2 way adjustment. For TEC 830 Micro side adjustment is available on most baseplates.

Use Phillips screwdriver to adjust screws.

- ① Side Adjustment
- ③ Height Adjustment

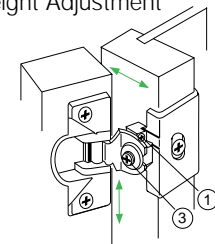

TEC 830

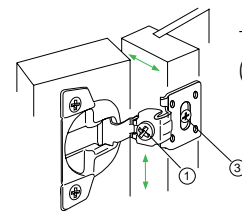

TEC 860
(2 piece)

Snap-On 3000 Series

Allows for three-way adjustments in the hinge arm. The side adjustment is a micro adjustment. The depth and height adjustment is held by a grid system.

Use #2 POZIdrive screwdriver to adjust screws.

- ① Side Adjustment
- ② Depth Adjustment
- ③ Height Adjustment

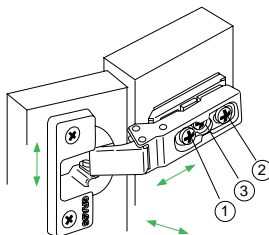

G100 Slide-On Series

Allows for three way adjustment. The side adjustment is a micro adjustment on the hinge arm. The height and depth are located on the baseplate to allow for 3-dimensional adjustment.

Use #2 POZIdrive screwdriver to adjust screws.

- ① Side Adjustment
- ② Depth Adjustment

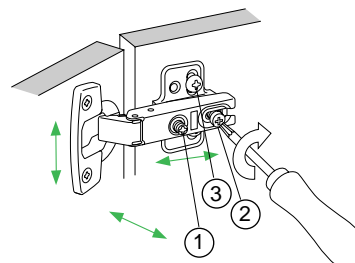

Atlas 961/963 Hinge Adjustments

Allows for two way adjustment. Height adjustment available with Euro screw version.

Use Phillips screwdriver to adjust screws.

- ① Side Adjustment
- ② Height Adjustment

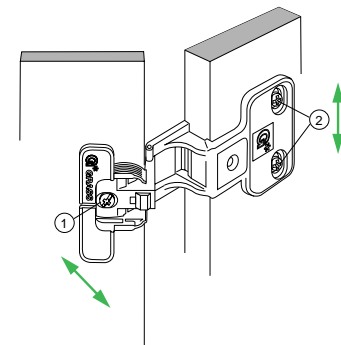

Technical Information

Door Overlay

All Grass hinges are set in neutral position, (no adjustment in the hinge arm has been utilized). The baseplate height of 1.3mm (= lowest baseplate height) represents the base measurement for the hinge cup overlay. Hinge cup overlay plus cup drilling distance equals door overlay. The possible cup drilling distance is stated on each catalog page.

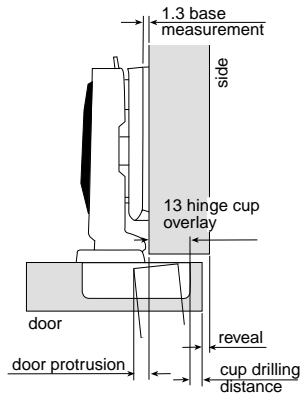

Overlay, zero-crank

The hinge cup overlay (in neutral position) is 13mm, unless otherwise stated in the catalog. The side adjustment screw allows for an adjustment of ± 2 mm.

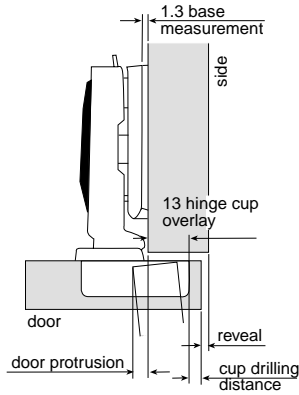

Half-Overlay, 8mm crank

The hinge cup overlay (in neutral position) is 5mm, unless otherwise stated in the catalog. The side adjustment screw allows for an adjustment of ± 2 mm.

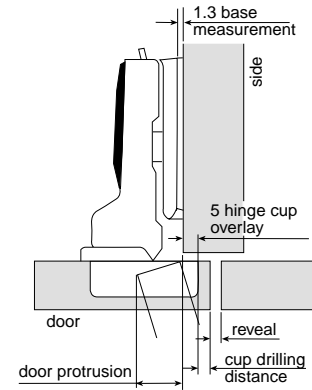

Inset, 16mm crank

There is no hinge cup overlay. The hinge cup clearance is stated in the catalog. The side adjustment screw allows for an adjustment of ± 2 mm.

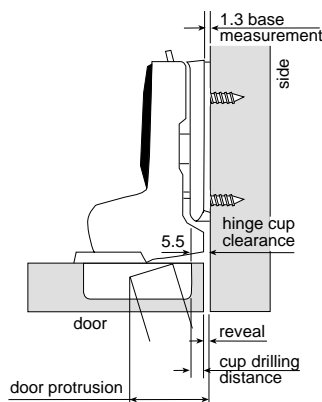

Note: For inset doors the baseplate setback is increased by the thickness of the door material. For 300, 600, and 3000 Series, the baseplate setback is increased by the thickness of the door material +2mm.

Space Requirement for Hinge

Mounting of hinge arm on the side panel requires a certain amount of space. Measurements "a" and "b" are given on each catalog page. Space requirement for hinge changes when side adjustment is used and

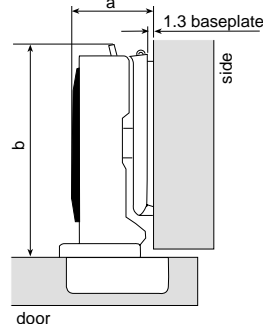

Door Clearance/Door Protrusion

The door clearance and door protrusion vary according to the hinge application in use and are stated on each of the catalog pages.

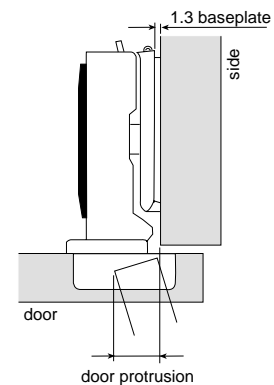

Calculating Baseplate Distance

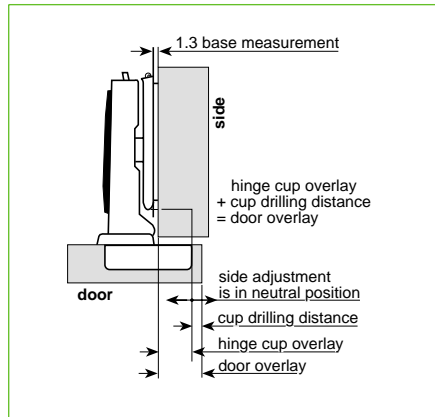

Example: Using 3803VS Hinge with Cup Drilling Distance of a 3.5mm Baseplate Calculation

hinge cup overlay (from catalog)	13.0mm
+ cup drilling distance	3.5mm
<hr/>	
	= 16.5mm
- desired door overlay	14.5mm
<hr/>	
thickness adjustment	= 2.0mm
+ thinnest baseplate (from catalog)	1.3mm
<hr/>	
baseplate thickness	= 3.3mm

Choose the baseplate nearest to this thickness. In this case 4.3mm.

Adjusting Cup Drilling Distance

baseplate thickness	4.3mm
+ desired door overlay	14.5mm
<hr/>	
	= 18.8mm
- hinge cup overlay (from catalog)	13.0mm
<hr/>	
	= 5.8mm
- thinnest baseplate (from catalog)	1.3mm
<hr/>	
cup drilling distance	= 4.5mm

For this application use a 4.3mm baseplate with 4.5mm cup drilling distance on the 3803 hinge.

Recommended Number of Hinges per Door Systems 100, 300, 3000, and 860

The number of hinges required depends on the size, weight and quality of the door. The distance between the hinges should be spaced as wide as possible. Use the diagram below to determine number of hinges needed.

- For doors to 24" wide, weighing up to 20lbs. - 2 hinges
- 20 - 40 lbs.- 3 hinges
- 40 - 60 lbs.- 4 hinges

These recommendations are for doors without accessory attachments only.

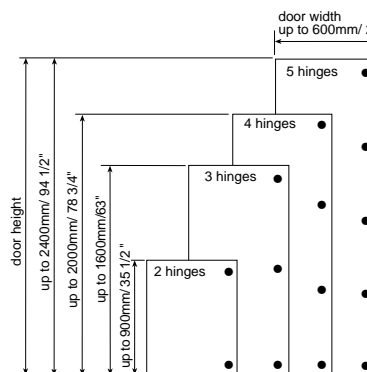

Exceptions to number of hinge recommendations

In abusive environments such as schools and hospitals:

- additional hinges should be added if doors are near the border line of size or weight chart.
- it is best to keep doors to a maximum of 508mm (20") in width. This prevents undue leverage against the doors.

In abusive environments, use the GRASS Atlas 961 Hinge.

Do's & Don'ts of Hinge and Baseplate Applications

Do's

- Use POZIdrive screwdriver for adjusting all frameless hinges.
- Attach baseplate using ALL available screw holes.
- Keep hinges as close to top and bottom of door as possible. Maximum recommended distance 75mm (3") from end of door.
- Make sure hinge arm is 90 degrees to door.
- Make sure doors do not bind when opening.
- Make a trial mounting to ensure accuracy.

Don'ts

- Don't exceed maximum cup drilling distance. Door will bind on hinge.
- Don't overuse the hinge adjustments.
- Don't overload the door (mirrors, racks, etc.)
- Avoid doors which are wider than they are tall.
- Don't over tighten the wood screws.
- Don't use Phillips screwdriver to adjust frameless hinges.